

Replaces all previous versions

STILLAGES AND CAGES



- Stackable and rackable, our pallets are space saving.
- Either on self locating pallet feet, or with bearers to fit into racking, they allow full use of available floor space.
- Product and materials can be stored and handled more securely in JNI Pallet Systems
- The rigid tubular steel construction combined with suitable cladding (mesh, sheet steel, timber)
- A safe and lasting solution for your materials handling problems – sturdy in construction and low in cost.
- Choose from our extensive standard range or have us custom design a solution to suit your specific needs.



Series 90

DIMENSIONS:

1168 W x 1035 H x 1168 D mm Overall External Dimensions

All Pallets have 120mm Ground Clearance

Internal Storage Height: 825mm



Series 90B

DIMENSIONS:

1076 W x 985 H x 1076 D mm Overall External Dimensions

All Pallets have 120mm Ground Clearance

Internal Storage Height: 825mm



Series 90C

DIMENSIONS:

1168 W x 1070 H x 1168 D mm Overall External Dimensions

All Pallets have 120mm Ground Clearance

Internal Storage Height: 910mm

Our policy of constant product improvement may lead to changes to specifications/prices without notice.

Replaces all previous versions

STILLAGES AND CAGES



SERIES 90 - Steel Pallet Cages

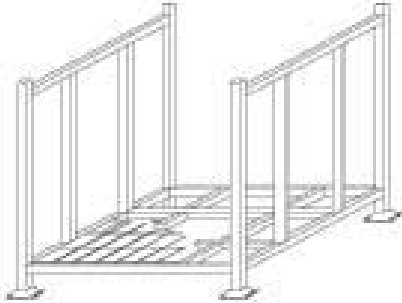

A-104

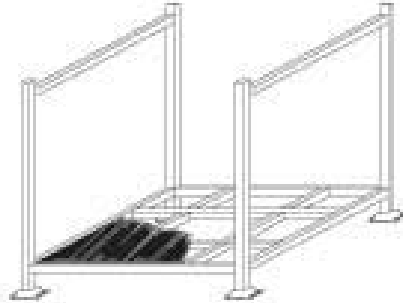

A-105

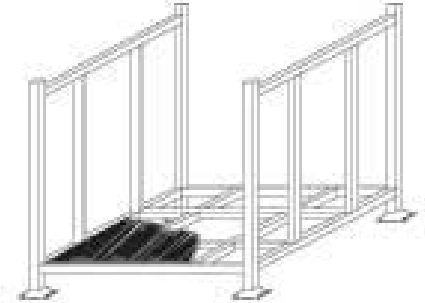

A-106

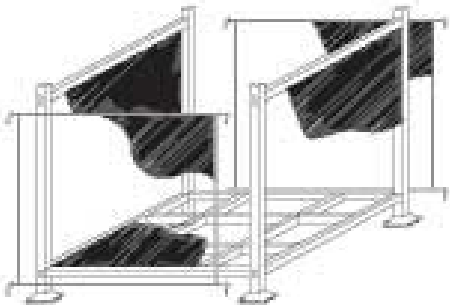

B-204

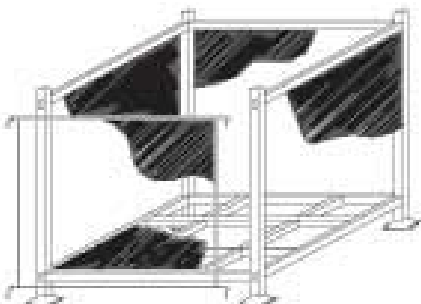

C-304



DIMENSIONS:

1168 W x 1035 H x 1168 D Overall External Dimensions
 All Pallets have 120mm Ground Clearance
 Internal Storage Height: 825 mm

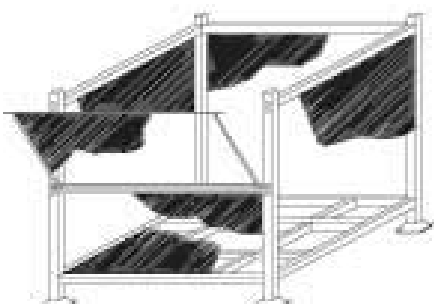

D-404

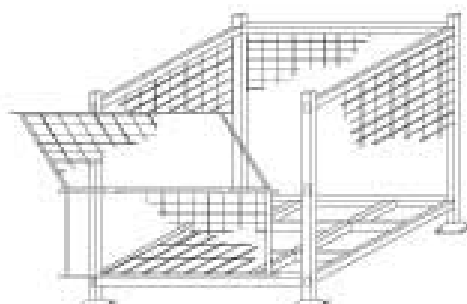

D-405

Our policy of constant product improvement may lead to changes to specifications/prices without notice.

Replaces all previous versions

STILLAGES AND CAGES



SERIES 90 - Steel Pallet Cages

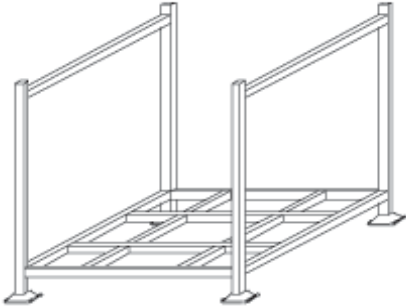

A-101

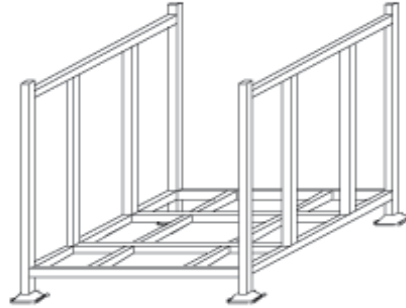

A-102

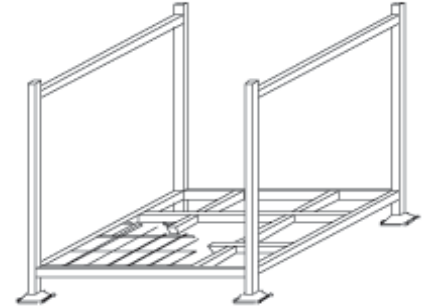

A-103

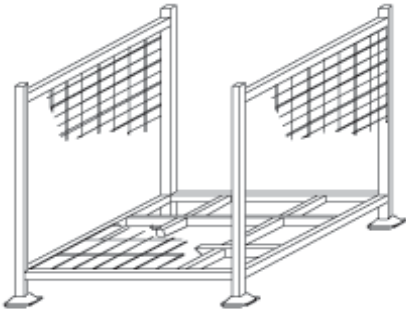

B-201

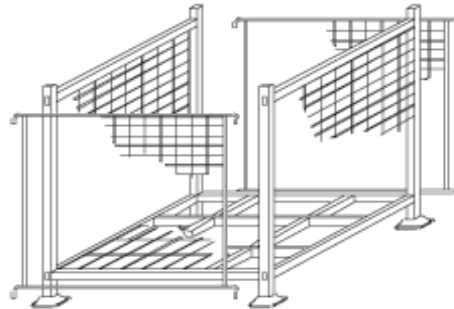

B-202

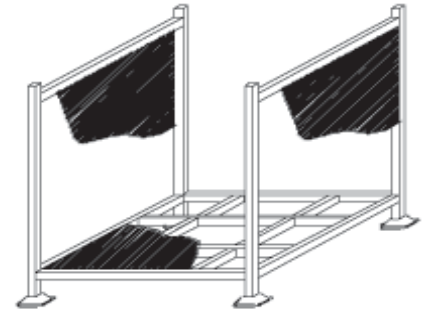

B-203

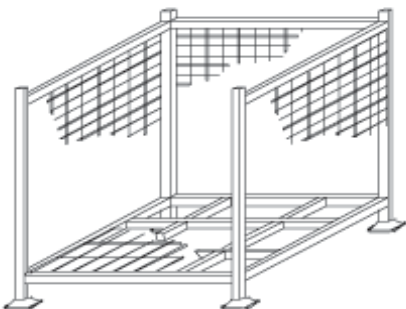

C-301

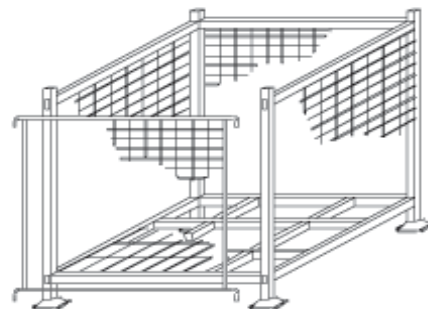

C-302

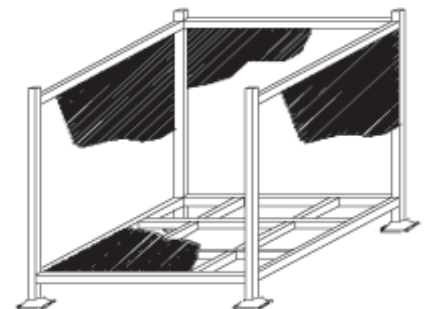

C-303

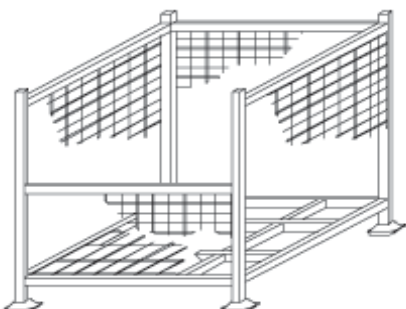

D-401

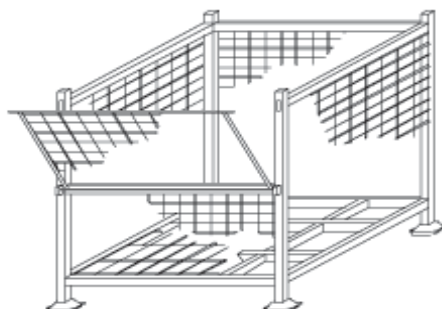

D-402

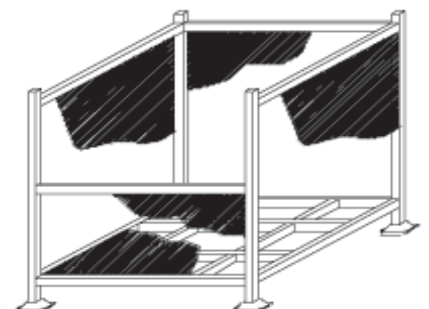

D-403

Our policy of constant product improvement may lead to changes to specifications/prices without notice.