

Replaces all previous versions

Effective 1st September 2004

All prices/specifications subject to change without notice.

All Prices Exclude Freight Charges & GST

We Also Provide:

- Work Benches
- Shelving Systems
- Racking Systems
- Labelling Systems
- Storage Systems
- Material Handling
and
- Trolleys

WEIGHING INDICATOR AD-4326A/B

- 1/10,000 displayed count resolution
- Full digital calibration (FDC)
- Mount on column, stand, desktop or wall
- Comparator output to remote display, buzzer or optional relays
- Selectable counting sample size: 5, 10, 20, 50, or 100
- Power: Battery and AC adaptor standard
- Auto power off (battery mode)
- Powers up to 6 load cells at 350Ω
- Optional bi-directional RS232C/Relay, Current Loop
- Meets or exceeds OIML Class III specifications
- EMI / RFI protected



PRICE
06136200
\$1195

ANALOG INPUT AND A/D CONVERSION

Input Sensitivity	0.2μV/d (Min.)
Input signal Range	-1mV--+15mV
Load Cell Excitation	5V DC ± 5%
Load Cell Drive Capacity	Up to 6 load cells at 350Ω / load cell (Max. 90mA)
Zero Temperature Coefficient	±(0.2μV + 0.0008% of dead load)/0C (typ.)
Span Temperature Coefficient	8ppm/0C of reading (typ.)
Non-Linearity	0.01% of full scale
Input Noise	±0.2μVp - p
Input Independence	10MΩ (Min.)
A/D Conversion Method	Integrating dual - slope type
A/D Resolution	40,000 counts (Max.)
A/D Conversion Rate	Approx. 5 times / second

DIGITAL SECTION

Weight Display	5 1/2 digits, 22mm / 0.87" (H) LCD
Comparator Display	LCD
Display Resolution	10,00 counts (Max.)
Minimum Division	Times x1, x2, x10, x20, x50
Maximum Display	199980

Remember - choose indicator from this page to go with the base on the opposite page



PRICE
06137200
\$1495



WEIGHING INDICATOR AD-4327A/B

- 1/10,000 displayed count resolution
- Water and dust resistant to NEMA4 / IP65
- Full digital calibration (FDC)
- Mount on column, stand, desktop or wall
- Built-in comparator buzzer
- Selectable counting sample sizes: 5, 10, 20, 50 or 100
- Power: Alkaline battery compatibility and AC adaptor standard
- Auto power off (battery mode)
- Powers up to 6 load cells at 350Ω
- Optional bi-directional RS-232C/Relay, Current Loop
- Meets or exceeds OIML Class III specifications
- EMI / RFI protected

ANALOG INPUT AND A/D CONVERSION

Input Sensitivity	0.2μV/d (Min.)
Input signal Range	-1mV--+15mV
Load Cell Excitation	5V DC ± 5%
Load Cell Drive Capacity	Up to 6 load cells at 350Ω / load cell (Max. 90mA)
Zero Temperature Coefficient	±(0.2μV + 0.0008% of dead load)/0C (typ.)
Span Temperature Coefficient	8ppm/0C of reading (typ.)
Non-Linearity	0.01% of full scale
Input Noise	±0.2μVp - p
Input Independence	10MΩ (Min.)
A/D Conversion Method	Integrating dual - slope type
A/D Resolution	40,000 counts (Max.)

DIGITAL SECTION

Weight Display	5 1/2 digits, 22mm / 0.87" (H) LCD
Comparator Display	LED (green / red / yellow)
Display Resolution	10,00 counts (Max.)
Minimum Division	Times x1, x2, x10, x20, x50
Maximum Display	199980
Under ZERO Indication	"_." minus display

Replaces all previous versions

Effective 1st September 2004

All prices/specifications subject to change without notice.

All Prices Exclude Freight Charges & GST

HEAVY DUTY LOW PROFILE PLATFORM SCALE

- Fast, accurate weighing and counting of bulk goods from all four sides
- Very low profile design allows for loading bulk goods from all four sides
- Loading ramps can be added if necessary as an optional extra
- Weighing platform can be supplied to suit individual applications within certain specification parameters
- Strong, robust design with a capacity up to 10,000kg
- Drop centre model available with the platform height above ground reduced to just 50mm
- Capacity - Maximum 3000kg (trade approved), Maximum 10,000kg (not for trade)
- Trade approved standard platform sizes: 1200 x 1200mm, 1500 x 1500 (non standard upon request)
- NSC Approval Certificate - 6/9C/220B
- Load cells - Nickel plated shear beam style



DIMENSIONS (mm)	FINISH	ORDER REF	PRICE
1200 x 1200	GALVANISED	03010201	\$2,895
1500 x 1500	GALVANISED	03010601	\$3,395



COMBINATION SCALES

ELP-3000 + HW-D COMBINATION

- Pre-calibrated to 3000kg x 1kg
- Performance plus from this combination
- Liquid crystal display with large characters
- Powered by dry batteries or optional AC adaptor
 - Full digital calibration
 - Fully approved for trade use
 - Comes with 1 year warranty
- Built-in comparator to enable easy packing and checking

CHECK WEIGHT CONTROLLER CW SERIES

You're considering purchasing a Check Weighing scale? Until now you had two options. One was to purchase a "Weights and Measures" approved Check Weighing scale and receive the quality and reliability this standard guarantees. The other was to save money by purchasing a cheap, non Weights and Measures approved scale but at a considerable risk. The introduction of the CW Series provides you with another, more sensible option.

CAPACITY	DISPLAY	WEIGHING PAN SIZE (mm)	ORDER REF	PRICE
3/6kg x 1/2g	VFD	300 x 280	06309400	\$895.00
6/15kg x 2/5g	VFD	300 x 280	06309500	\$895.00
15/30kg x 5/10g	VFD	300 x 280	06309600	\$895.00



Replaces all previous versions

Effective 1st September 2004

All prices/specifications subject to change without notice.

All Prices Exclude Freight Charges & GST



PLATFORM SCALE HW KGL & KGV SERIES

- Large clear display - LCD or VDF
- Mains or battery operation (depends on model)
- Four capacities with 3 platform sizes
- High resolution - minimum 1/10,000
- Standard RS232C serial data interface
- Built in comparator with batching software
- Weighing, counting, percentage modes
- Accumulation of weighings and total weight
- Preset tare can be entered via keypad
- Personal and animal weighing codes
- Display hold facility - manual or automatic

WEIGHING CAPACITY (kg)	MIN. WEIGHING (1 DIGIT) (g)	WEIGHING PAN SIZE W x D (mm)	DIMENSIONS W x D x H (mm)	ORDER REF	PRICE
10	1	250 x 250	550 x 420 x 380	03160100	\$995
60	5	330 x 424	850 x 440 x 290	03160300	\$1195
100	10	390 x 530	850 x 440 x 290	03160400	\$1295
200	20	390 x 530	850 x 440 x 290	03160500	\$1295
10	1	250 x 250	550 x 420 x 380	03161100	\$1095
60	5	330 x 424	850 x 440 x 290	03161300	\$1295
100	10	390 x 530	850 x 440 x 290	03161400	\$1395
220	20	390 x 530	850 x 440 x 290	03161500	\$1395

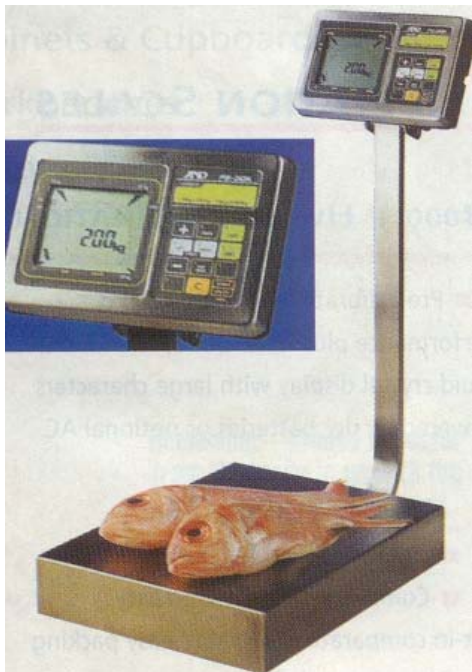

WATERPROOF CHECK WEIGHING SCALES FS-KL SERIES

- Sealed enclosure and load cell for wet areas
- Exclusive analogue sweep LCD graphically shows weight while filling. Large digital display precisely shows the result
- Display head tilts for ease of reading
- Battery or mains power. Battery lasts up to 400 hours, with alkaline batteries
- Auto battery power down is user selectable
- Full digital calibration
- Eight preset memories for target weight and high/low set point values
- Numeric keypad allows quick entry of Target Weight and high/low set point values
- Approved by the National Standard Commission for trade use and manufactured to Australian standards -ASO9001 requirements

CAPACITY (kg)	PAN SIZE (mm)	WEIGHT (kg)	ORDER REF	PRICE
150 x 50g	330 x 424	16	03091100	\$1,695
60 x 20g	390 x 530	23	03092100	\$1,795
30 x 10g	390 x 530	23	03093100	\$1,795

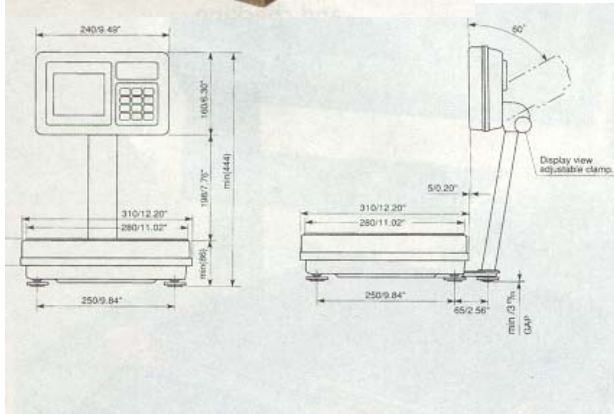

LCD Display: Digital section - 7 segment x 5 digits
 16mm height Analogue sweep display section with 31 segments

CHECK WEIGHING SCALES FS SERIES



- Easy operation, quick response time
- Analogue Sweep LCD and Tilt Head
- Waterproof stainless Steel Construction with sealed Load Cell
- Dual range for greater accuracy
- Battery or AC adaptor operation
- Backlit display optional for low light conditions

CAPACITY (kg)	RESOLUTION	PAN SIZE W x D (mm)	ORDER REF	PRICE
6	3kg/1g - 6kg/2g	310 x 310	03073100	\$1,545
15	6kg/2g - 15kg/5g	310 x 310	03073200	\$1,545
30	15kg/5g - 30kg/10g	310 x 310	03073300	\$1,545

Replaces all previous versions

Effective 1st September 2004

All prices/specifications subject to change without notice.

All Prices Exclude Freight Charges & GST

COUNTING SCALES

- High quality, fully featured counting scales
- 10-key pad for direct entry of Tare weight, piece weight and sample size
- Automatic Counting Accuracy Improvement (ACAI) feature for excellent counting accuracy
- Comparator function for use in packaging operations. Results on display, buzzer or optional relay output
- 6 models in 5 capacities to meet your needs
- Accumulation memory for running totals
- 3 power sources - AC adaptor, dry cell battery (standard operation), optional rechargeable battery. Battery power is particularly useful in portable operations and areas with power problems
- Automatic power off to conserve battery life
- Large, easy to read, wide angle LCD
- Intuitive operation for ease of use and reduced training time
- Possible to disable all key functions, except [ON/OFF]; [ZERO]; [TARE]; [SAMPLE]; [ENTER/M+PRT], for error free operation

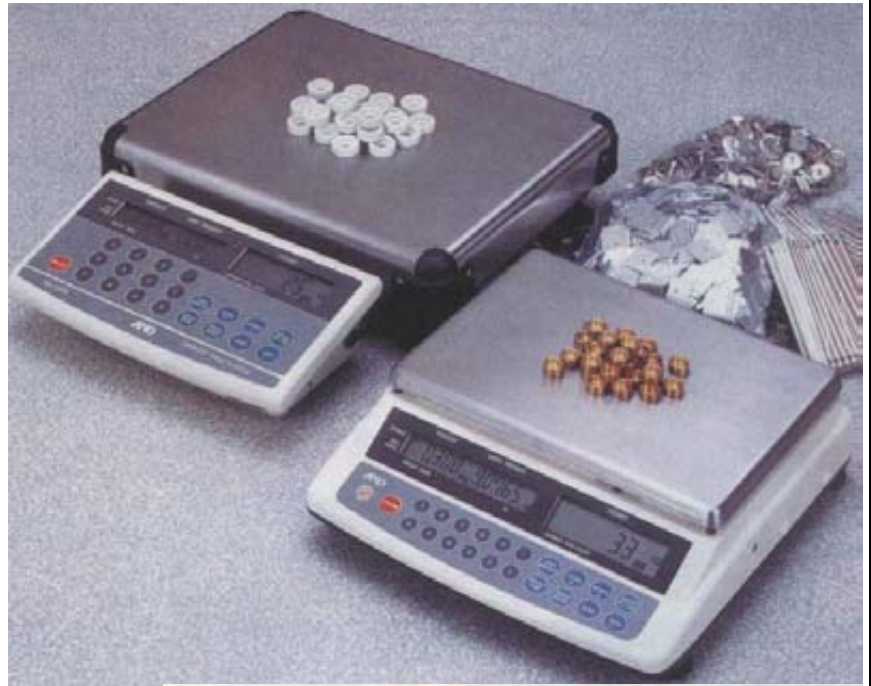

FC-I SERIES

The FC-i series scales have a user-friendly function to set and recall the unit weight using the navigation system in the LED. Simply use the "SAMPLE," "KEY-BOARD," and "ID" keys to use the counting scales with ease, and without error.

The VFD display for piece counting allows easy viewing thanks to its large numbers and subdisplay showing weight, comparator result, unit weight, ID number, and item code. For the item code, you can use numeric or alphanumeric letters. For more accurate counting results, the ACAI (automatic counting accuracy improvement) is very useful for taking the unit weight by averaging bigger sample numbers for the sample weight to be weighed.

The standard RS-232C interface and newly developed UFC function (universal flex coms) together expand the recording application. For increased user flexibility, you can connect to and print the counting result from any FC-i series scale to an external dumb printer.



FC SERIES

CAPACITY / RESOLUTION (kg)	PAN SIZE W x D (mm)	ORDER	PRICE REF	SERIES
5000g x 0.01g	300 x 280	06020400	\$1995	FC
10kg x 0.02g	300 x 280	06020500	\$1995	FC
20kg x 0.04g	300 x 280	06020600	\$1995	FC
50kg x 0.1g	300 x 280	06020700	\$1995	FC

HC SERIES

The HC series is designed for the cost conscious user. It is compact and portable. It's low profile speeds operation and saves space.



HC SERIES

CAPACITY / RESOLUTION (kg)	PAN SIZE W x D (mm)	ORDER	PRICE REF	SERIES
3 x 0.5g	216 x 294	06011600	\$915	HC
6 x 1g	216 x 294	06011700	\$915	HC
12 x 2g	216 x 294	06011800	\$915	HC

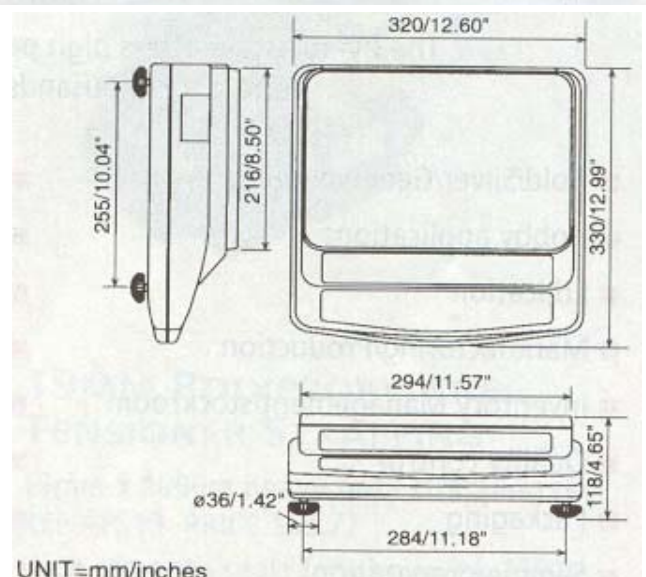

UNIT=mm/inches

Sample Size: 5, 10, 25, 50, 100 or user selectable Number. Maximum Count (pieces): 30,000 or 120,000. Display: LCD - 17mm character height. Power: AC Adaptor, 6 x 'C' size dry batteries or optional rechargeable battery pack (AD-1681). Battery Life: Approximately 100 hours with manganese type cells, 200 hours with alkaline type cells, 20 hours with rechargeable battery pack (AD-1681). Standard Accessories: Manual & AC Adaptor

Replaces all previous versions

Effective 1st September 2004

All prices/specifications subject to change without notice.

All Prices Exclude Freight Charges & GST

COMPACT SCALE HL SERIES

- High resolution
- Solid & reliable design
- Large square detachable weighing pan
- Clear LCD display (8mm)
- Accurate reading in wide temperature range
- Portable (6 AA-type batteries, batteries not included)

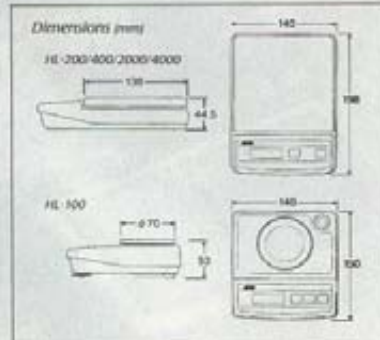

CAPACITY (kg)	PAN SIZE (mm)	WEIGHT APPROX (kg)	ORDER REF	PRICE
100 x 0.01g	Ø70	500	06310101	\$465
200 x 0.1g	136 x 136	500	06310100	\$345
400 x 0.1g	136 x 136	500	06310300	\$395
2000 x 1g	136 x 136	500	06310200	\$345
4000 x 1g	136 x 136	500	06310400	\$395

- Stability indicator
- Separate keys for Power & Re-Zero
- Auto Power Off
- Standard carrying case (for HL-100)

■ Optional AC adaptor:
 REF ECTP:124 PRICE \$50.00



CAPACITY (kg)	PAN SIZE W x D (mm)	WEIGHT APPROX (kg)	ORDER REF	PRICE
2000 x 1g	230 x 190	3.0	06300200	\$395
5000 x 2g	230 x 190	3.0	06300300	\$395
10k x 0.05	230 x 190	3.0	06300400	\$395
20 x 0.01	230 x 190	3.0	06300500	\$395
50 x 0.01	230 x 190	3.0	06300600	\$435
30 x 0.02	230 x 190	3.0	06300700	\$495

Display: LCD 25mm/0.98 inches high. Battery Life: 600 hours Manganese type cells, 1200 hours with Alkaline type cells. Power: 6 x R20P/LR20/"D" size batteries or AC adaptor.

DIGITAL SCALE SK SERIES

Unlimited applications, hardware stores, roadside stands, offices, industries, warehouses

- Splash proof (driptight)
- Designed to meet Weights & Measures regulations
- Portable (6 D type batteries, batteries not included)
- Low battery indication
- Auto power off

Dimensions (mm)

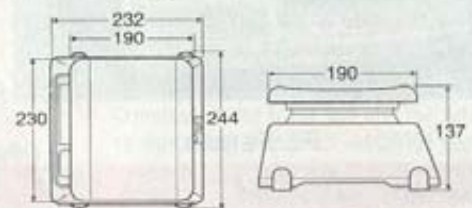

POCKET SCALE PV-100

The PV-100 scale offers high performance at a low price. Perfect for thousands of applications:

- Gold/Silver/Gem weighing
- Hobby applications
- Education
- Manufacturing/Production
- Inventory Management/stockroom
- Quality control
- Packaging
- Sample preparation
- Environmental testing
- Paint, ink & chemical mixing
- Portion control and dietary management
- Field testing
- Checkweighing
- Postage scale
- Any application requiring portability

GRAM	PAN SIZE W x D (mm)	DIMENSIONS W x D x H (mm)	ORDER REF	PRICE
100 x 0.1	86.2 x 76.2	76.2 x 134.6 x 20.3	04000100	\$245

Power Requirement: 2 AAA Size Alkaline batteries (standard). Typical Battery Life: 40 hours with Alkaline batteries

