

Replaces all previous versions

Effective 23rd August 2006

# SAFETY & OPERATING PRINCIPLES FOR DRUM STORAGE & DISPENSING



A complete line of Safety Drum Vents, Bonding and Grounding Wire Assemblies, Transfer Pumps, Faucets, and Valves provide all the accessories you need to safely store or dispense flammable liquids from standard 60 or 205 litre (55-gallon) drums.

All products exceed OSHA standards and are available in various sizes and materials to suit your specific application.

Flammable liquids give off vapours which build up excessive pressures in closed drums and can cause explosions and fire when exposed to heat.

For this reason, safety drum vents and/or fill units are installed in the drum bung openings to automatically relieve excessive pressure.

They also provide vacuum relief to facilitate withdrawal of liquids. The vents feature perforated-metal flash arresters to prevent the propagation of outside sources of ignition into the drums.

Other safety hazards may exist when dispensing liquids from drums and containers.

Static electricity charges may be generated when liquids are transferred.

The possibility of developing a static spark between the containers can be eliminated by utilizing proper bonding and grounding methods.

The diagrams illustrate correct grounding/bonding techniques for both faucets and transfer pump dispensing operations. It is important to note that when dispensing by faucet, the faucet spout must be brought into direct contact with the fill opening of the receiving container to form a suitable bond. Likewise, if using a pump, the dispensing hose must incorporate a wire insert running the length of the hose between the pump nozzle and the receiving container.

These storage and dispensing procedures, when coupled with the connection of the drum to suitable ground, will ensure the safe storage and dispensing of flammable liquids from drums.

Proper Bonding/Grounding for Dispensing by Faucet

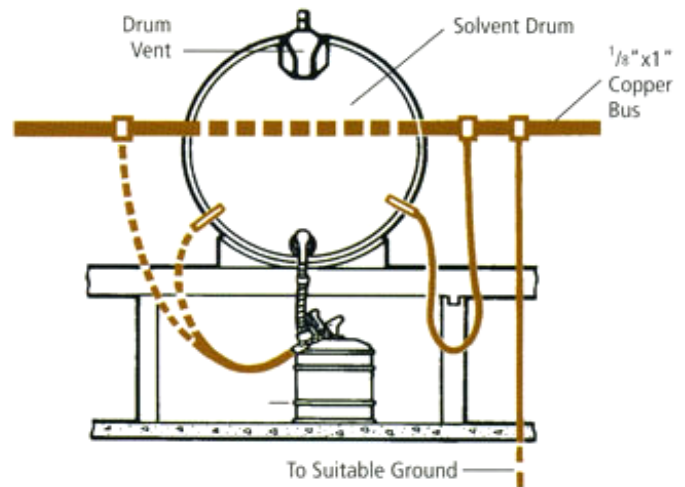

Proper Bonding/Grounding for Dispensing by Pump

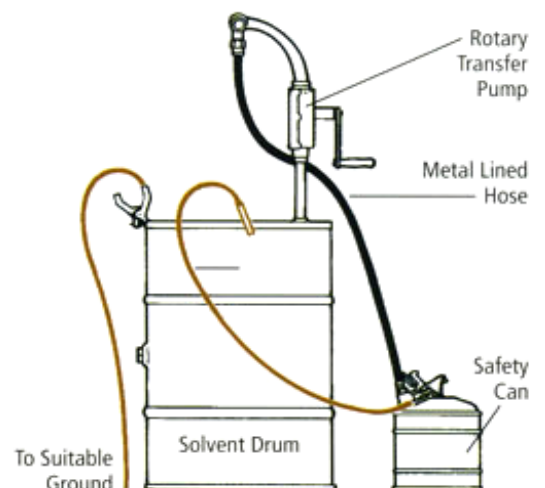

All prices/specifications subject to change without notice.