

Replaces all previous versions

Effective 20th June 2008

Truck and Railcar Mobile Access Platforms

TTX - Mobile Truck Access Unit

Portable versatile solution for tank truck access

The TTX unit has the smaller cage unit on top and a smaller base - it is used only for tank truck access



Vehicles used on:

Tank Trucks
Hopper Cars
Petroleum Trucks

Uses:

Sampling
Loading
Inspection
Unloading
Venting
Connect Hoses



FEATURES:

Unique wheel design allows for a tighter turning radius and easier maneuvering to simplify spotting.

Slip-Resistant platform provides a self-cleaning, slip-resistant surface for improved safety.

Can be used on a wide range of vehicles.

Can be modified to meet your requirements.

227 kg load capacity.

Hand winch allows for easy raising and lowering of platform.

Leveling jacks on outriggers provide a more secure base.

Platform has heavy rubber bumpers on contact surface to protect vehicles from damage.



All prices / specifications subject to change without notice.

ADD 10% GST AUSTRALIA ONLY

Replaces all previous versions

Effective 20th June 2008

**TOTAL
 UNIT
 WEIGHT : 340 KG**

**LOAD
 CAPACITY : 227 KG**

The TXX-1 meets or exceeds
 OSHA regulations as we
 interpret them.

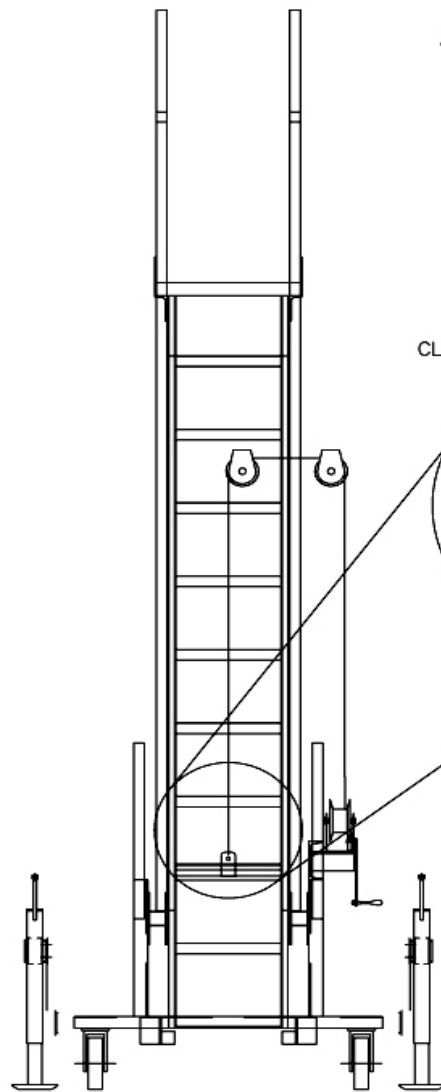
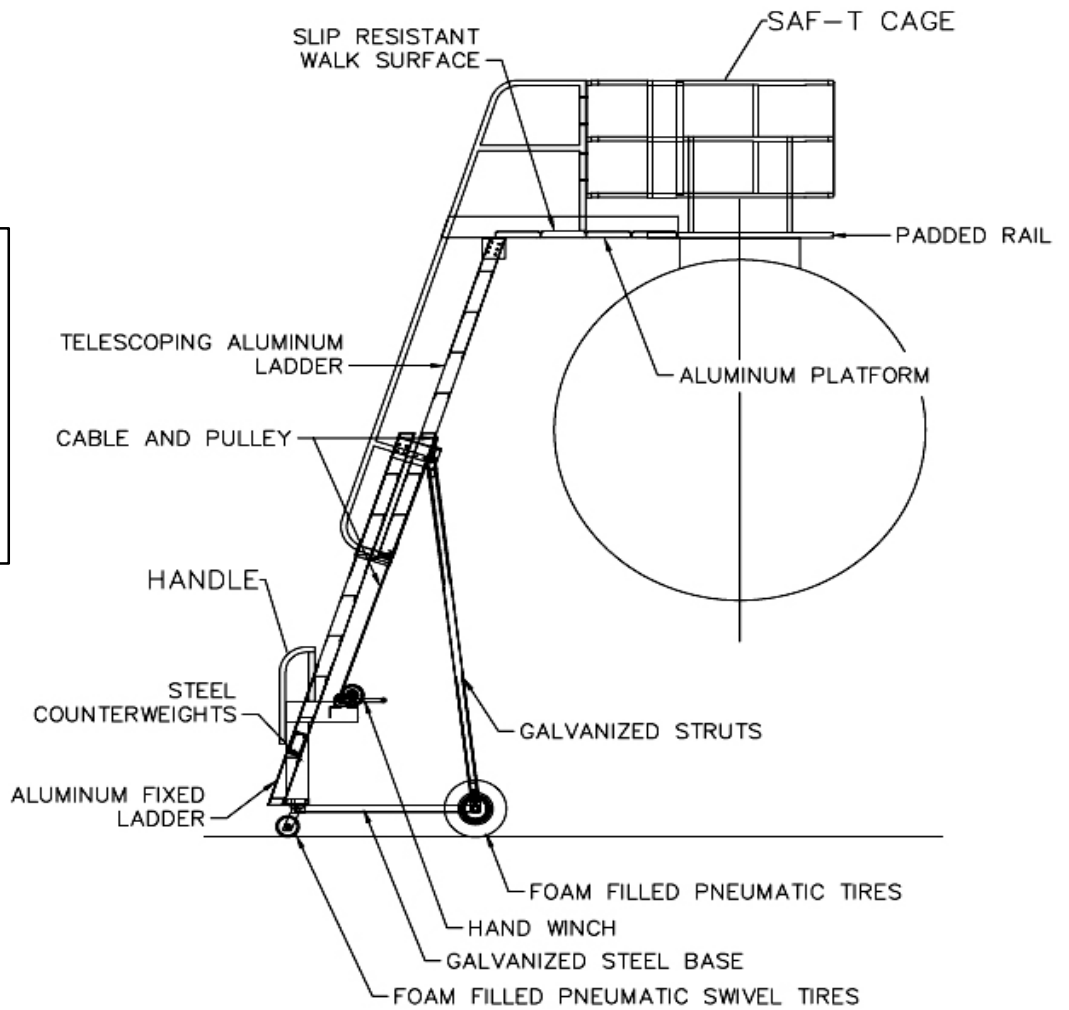

FRONT VIEW OF TTX-1

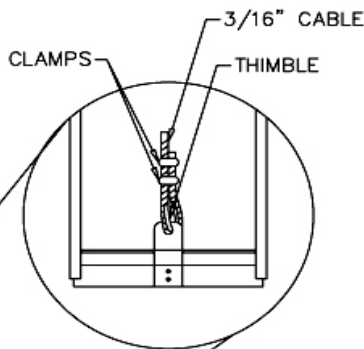

BACK VIEW OF
 BOTTOM STEP OF
 FLY SECTION

Periodically grease
 winch gears; See addenda,
 manufacturer's literature.

All prices / specifications subject to change without notice.

ADD 10% GST AUSTRALIA ONLY

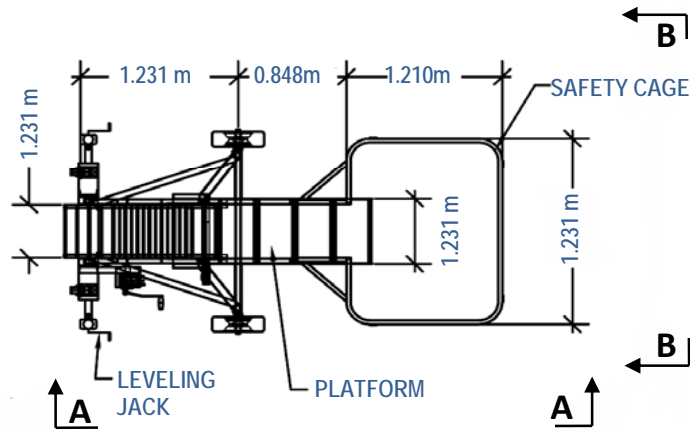

PLAN VIEW

NOTES:

- 1) LADDER & PLATFORM TO BE ALUMINUM CONSTRUCTION.
- 2) BASE TO BE GALVANIZED STEEL CONSTRUCTION.
- 3) WALK SURFACE ON BASE & PLATFORM TO BE SLIP RESISTANT
- 4) UNIT IS NO SELF SUPPORTING AND MUST REST ON A VEHICLE

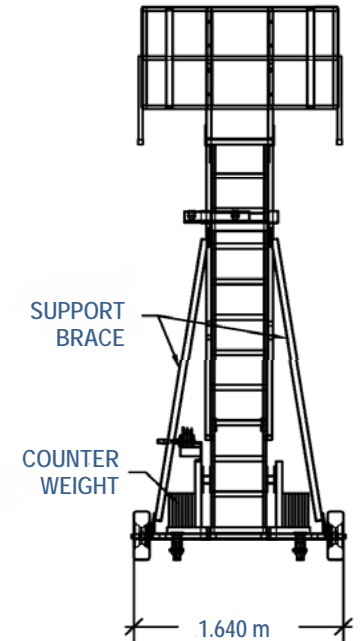

SECTION "B-B"

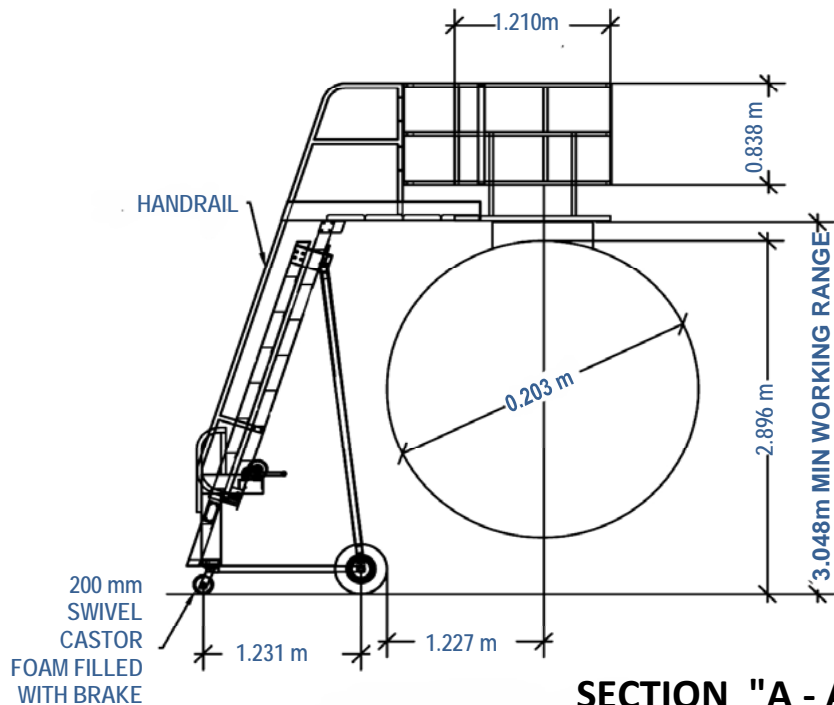

SECTION "A - A"

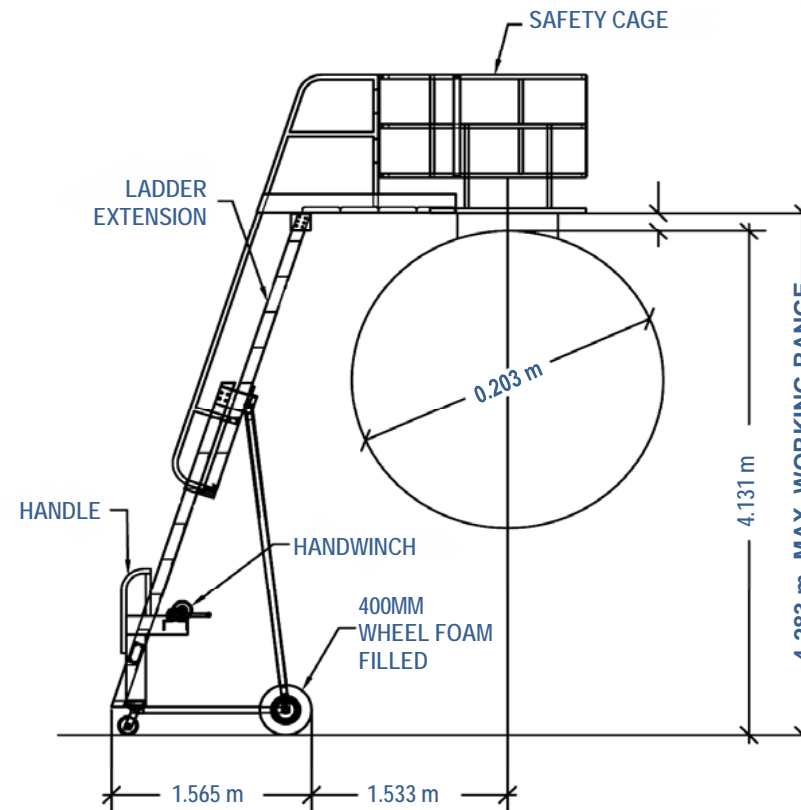

SECTION "A-A"