

Replaces all previous versions

Effective 1st February 2005

Total Drum Handling Safety

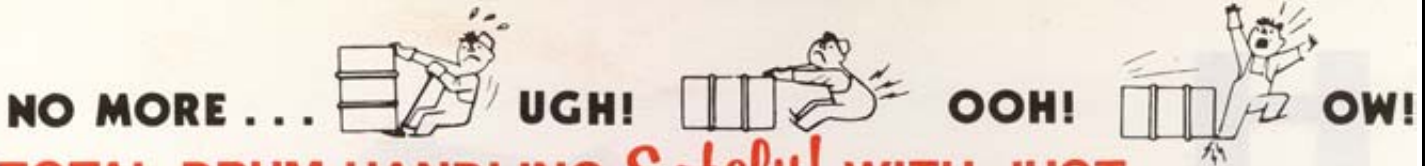

TOTAL DRUM HANDLING Safely! WITH JUST ONE MAN & ONE APPLIANCE !

The rim grip drum lifter handles a wide variety of drum styles and sizes without complicated adjustments or exchanging attachments.

- Drums are raised and transported simply by engaging the screw operated rim clamp.
- When tipping a webbing strap and quick action buckle are applied.
- Raise drum hydraulically with a choice of either foot, air or battery electric operation.
- Tip drum precisely through the fully enclosed chain drive and crank operated worm gearbox.
- Load and off load pallets and racking.
- Transport drums about your works on large diameter wheels in a wide range of materials.
- Truck lock type brake fitted.

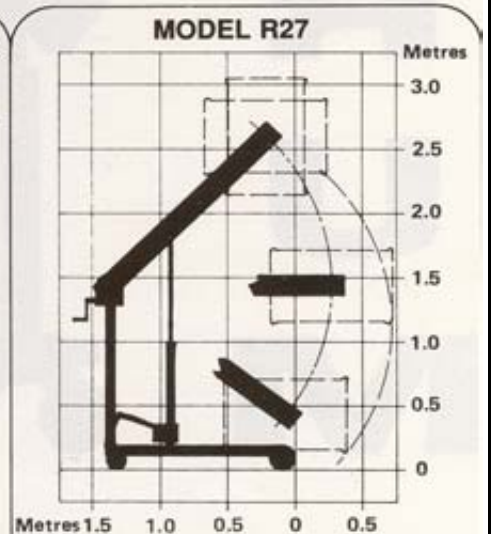
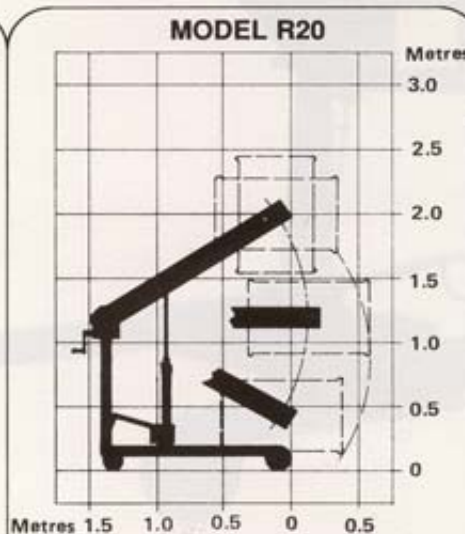
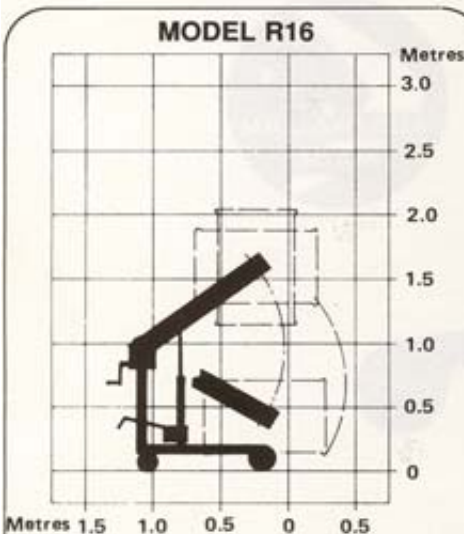

SPECIFICATIONS

MAXIMUM LOAD	350kg
LENGTH O/ALL	1400mm
WIDTH O/ALL	1050mm
STRADDLE WIDTH	850mm
HEIGHT	1060mm
WHEEL DIA.	200mm/150mm
ROTATION	320°
MAX. ELEVATION ROTATE CENTRE	1600mm

SPECIFICATIONS

MAXIMUM LOAD	350kg
LENGTH O/ALL	1750mm
WIDTH O/ALL	1050mm
STRADDLE WIDTH	850mm
HEIGHT	1310mm
WHEEL DIA.	200mm/150mm
ROTATION	320°
MAX. ELEVATION ROTATE CENTRE	2000mm

SPECIFICATIONS

MAXIMUM LOAD	350kg
LENGTH O/ALL	1780mm
WIDTH O/ALL	1050mm
STRADDLE WIDTH	850mm
HEIGHT	1540mm
WHEEL DIA.	200mm/150mm
ROTATION	320°
MAX. ELEVATION ROTATE CENTRE	2700mm