

Waste & Storage Bins Crane Bins

Type SCB Crane Bins

Heavy duty bins suitable for all waste products. Space saving shape allows bins to nest inside each other for transport and storage. Available in 1 tonne capacity made from 3mm plate or 2 tonne capacity made from 5mm plate. Bins are fitted with 2 way entry fork pockets allowing for emptying with forklifts fitted with rotator, as well as being fitted with crane lugs and upending lugs for emptying by crane. Available in either painted or zinc plated finish.

Options Available:

- Cast Iron or Rubber Wheels
- 4 Way Entry Pockets

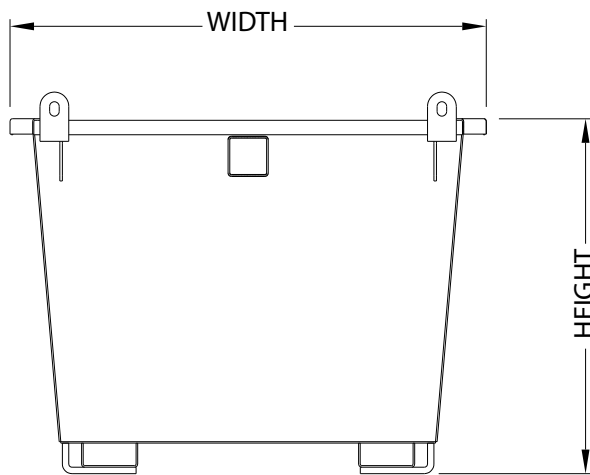

Type	Fork Pocket Size (mm)	Fork Pocket Centres (mm)	Capacity (cu. m)	SWL (kg)	Width (mm)	Length (mm)	Height (mm)	Unit Weight (kg)
SCB 112	165 x 65	585	0.75	1000	1200	1230	895	150
SCB 115	165 x 65	865	1.25	1000	1500	1230	1095	180
SCB 121	165 x 65	865	1.80	1000	2100	1230	1095	230
SCB 212	165 x 65	585	0.75	2000	1200	1230	895	220
SCB 215	165 x 65	865	1.25	2000	1500	1230	1095	290
SCB 221	165 x 65	865	1.80	2000	2100	1230	1095	380



Waste & Storage Bins **Crane Bins**

Type SSC Crane Bins

A heavy load capacity storage bin suitable for all manufacturing and construction sites. This versatile bin can be moved by crane, forklift or pallet truck.

Fitted with four way forklift pockets and corner crane lifting lugs, these bins can be stacked 4 high. The bin can be emptied by crane or a forklift fitted with carriage rotator.

Bins have corner drain holes, and are available in either painted or zinc plated finish.

Options Available:

- Cast Iron or Rubber Wheels (not stackable)
- No Drain Holes



SSC 800 and SSC 1000

Type	Capacity (cu. m)	SWL (kg)	Width (mm)	Length (mm)	Height (mm)	Unit Weight (kg)
SSC 400	0.4	2000	1250	1250	475	200
SSC 800	0.8	2000	1250	1250	775	220
SSC 1000	1.0	2000	1250	1250	925	240
SSC 1200	1.2	2000	1250	1250	1075	260

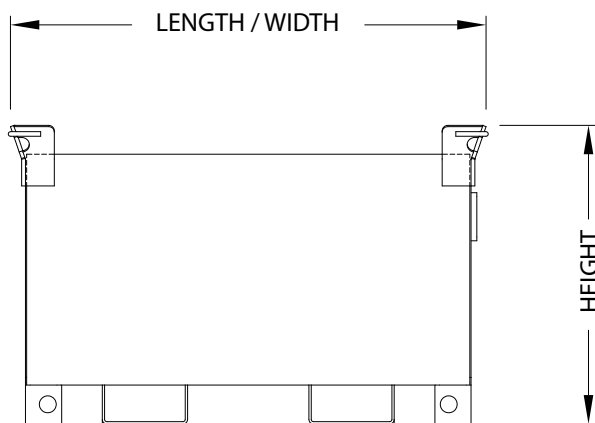

SSC 800



4 Way Pockets



SSC 1000

Waste & Storage Bins

Crane Bins

Type BWB Bulk Waste Bin

The BWB Bulk Waste Bin is ideal for building and mining sites using overhead cranes. This bin is available in three different sizes up to a maximum capacity of 14 tonne SWL. Enamel paint finish.

Note: BWB 50 supplied with lifting chains.

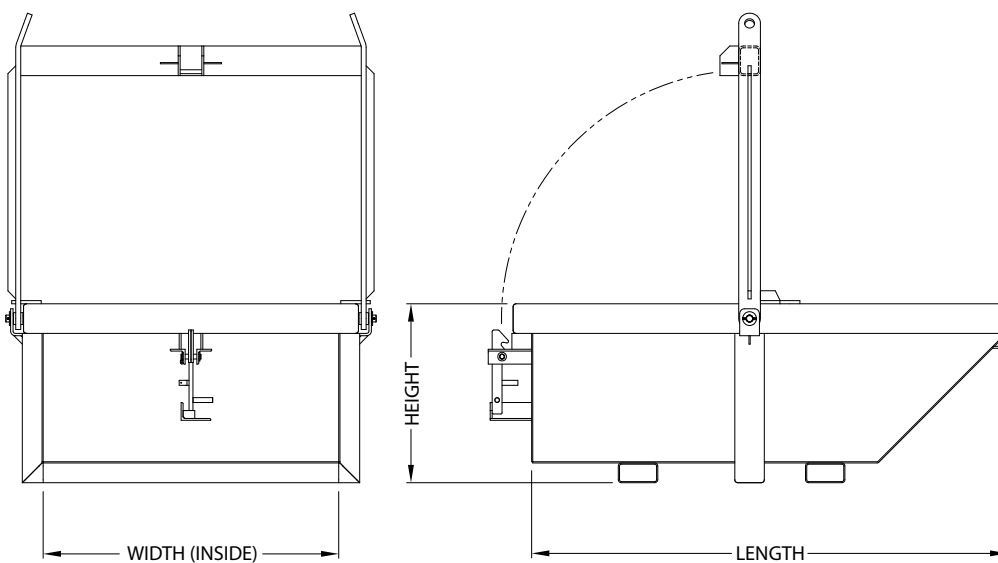

Type	Capacity (cu. m)	SWL (kg)	Width (mm)	Length (mm)	Height (mm)	Unit Weight (kg)
BWB 15	1.5	3000	1500	1800	830	560
BWB 30	3.0	5000	1500	2400	905	825
BWB 50	5.0	14,000	2400	3000	960	2560

Waste & Storage Bins

Crane Bins

Type CB 20 Crane Bin

The CB 20 bin is a heavy duty bin suitable for products such as sand, gravel, excavation waste and scrap metal.

The bin comes standard with 6 crane lugs for crane operation, and fork pockets are fitted for transport. Enamel paint finish.

Refer to table for full specifications.

- Fork Pocket Size: 165 mm x 65 mm
- Fork Pocket Centres: 725 mm



CB 20

Type CB 30 Crane Bin

With a larger capacity, the CB 30 has a higher safe working load. Enamel paint finish.

Refer to table for full specifications.

- Fork Pocket Size: 165 mm x 65 mm
- Fork Pocket Centres: 725 mm

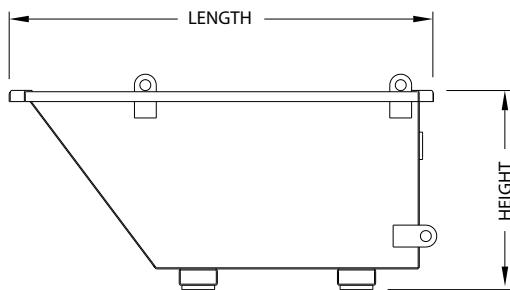

CB 30

Type CB 50 Crane Bin

Manufactured from 6 mm plate and reinforced with additional bracing, the CB 50 is an extremely heavy duty bin for large capacity volumes. Enamel paint finish.

Refer to table for full specifications.

- Fork Pocket Size: 185 mm x 85 mm
- Fork Pocket Centres: 950 mm

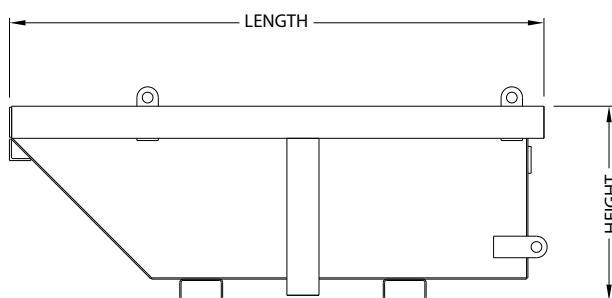

CB 50

Type	Capacity (cu. m)	SWL (kg)	Width (mm)	Length (mm)	Height (mm)	Unit Weight (kg)
CB 20	1.25	2000	1170	1924	905	310
CB 30	1.90	3000	1330	2155	1045	390
CB 50	2.0	5000	1660	2495	905	720

Waste & Storage Bins **Crane Bins**

Type NCB Crane Bin

A stackable bin designed for crane lifting and emptying. The stack legs allow for easy handling by forklift. Available in either painted or zinc plated finish.

- Safe Working Load: 1000 kg

Available Options

- Cast Iron or Rubber Wheels
- Drain holes
- Fork pockets



NCB 9

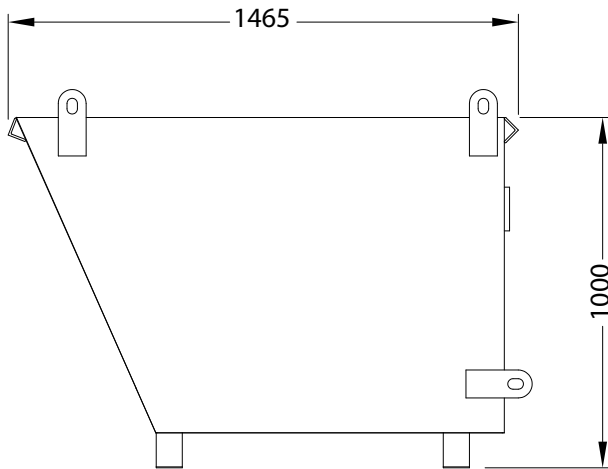

Type	Capacity (cu. m)	Width (mm)	Unit Weight (kg)
NCB 6	0.7	600	160
NCB 9	1.0	900	180
NCB 12	1.35	1200	190

Type CPB 6 Crane Bin

A compact, heavy duty stackable bin ideal in machine shops and foundries for component storage. Manufactured from 3mm plate and fitted with crane lugs, these bins are easily moved by forklift or crane. Available in either painted or zinc plated finish.

- Capacity: 0.23 cubic metres
- Safe Working Load: 1000 kg
- Unit Weight: 80 kg

Available Options

- Cast Iron or Rubber Wheels



CPB 6 Stacked

