

Crane & Overhead Lifting **Brick Cage**

Type BSN6 Brick Cage

The BSN6 Brick Cage is designed to convey pallets of bricks or similar loose products safely to a work location via overhead crane.

Suitable for 1200mm square pallets (1240mm clear inside), and up to 1500mm overall height. Zinc plated finish. The cage can be supplied as a fully assembled welded unit BSN6W or as a flat pack for self assembly BSN6F which is then bolted together.

- Safe Working Load: 2000 kg
- Lifting Points: 4 point lift
- Unit Weight: 255 kg



Flatpack

Specifications	Internal Width (mm)	Internal Depth (mm)	Internal Height (mm)	Overall Width (mm)	Overall Depth (mm)	Overall Height (mm)
BSN-6W - Welded	1240	1240	1500	1340	1340	1720
BSN-6F - Bolted	1240	1240	1500	1340	1340	1720

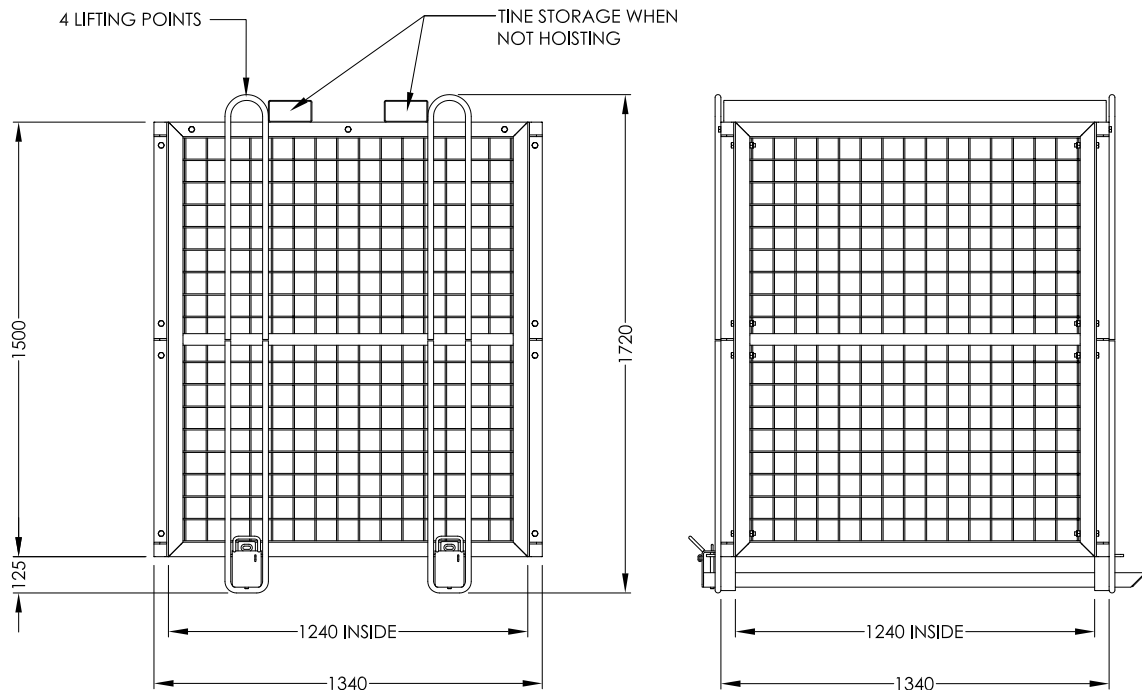

Crane & Overhead Lifting

Goods Cages

Type CSPN-01 Goods Cage

Safely convey loose or palletised goods using either forklift or crane. Full width gate allows for 1200mm square pallets to be placed inside. Fitted with crane lifting lugs, fork stirrups and interlocking feet, this versatile cage can also be safely stacked. Zinc plated finish.

- Safe Working Load: 1000 kg
- Unit Weight: 175 kg

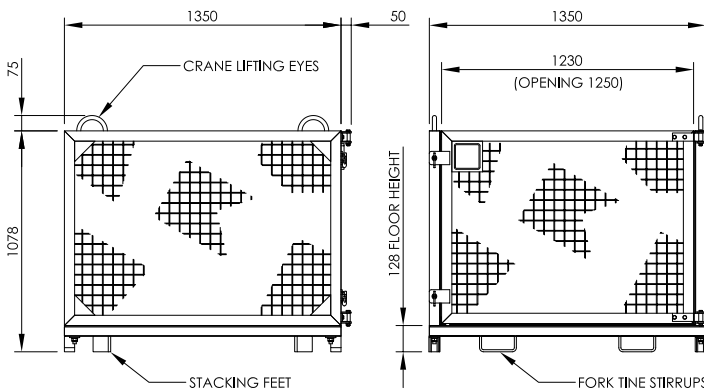

Type CGC-01 Goods Cage (No Gate Fitted)

The type CGC-01 Crane Goods Cage is a pallet size cage designed to transport goods using either a Forklift or Crane.

Stacking Feet underneath the Cage allow it to be stacked on top of each other – 3 high when empty, 2 high when full. Cage is supplied standard as a "Flatpack" for on site assembly, or may be fully assembled upon request. Zinc plated finish.

- Safe Working Load: 1000 kg
- Unit Weight: 132 kg

