

## 07

# PEDESTRIAN CONTROL



This section offers portable and temporary products designed to control the movement of pedestrians. Whether queuing at the theatre, separating people from vehicles or protecting them from hazards in the workplace. You should also look at Section 6 for our Port-a-guard range and Section 11 for our unique NEW Neata Airport Barriers.

If you still can't find what you require don't hesitate to phone us. Our helpful customer service staff are always willing to help with any of your enquiries.

You may also be interested in:



PEDESTRIAN SEPARATION



EXPANDING BARRIERS



MACHINERY GUARDING



AIRPORT BARRIERS

## ECONO-BELT

Popular with hotels, nightclubs, sporting venues, airports and wherever queue control is required, Econo-belt offers an economical alternative to our premium retracta-belt range.

Manufactured from 0.6mm polished stainless steel with a cast iron base, the Econo-belt is available with 3 belt options – Black, Red or Blue.

The belt mechanism extends to 2 metres, has 4-way connectivity and is compatible with most other retractable belt systems.

Available in 3 colours only, the Econo-belt is shipped flat packed and weighs 8kgs. Extension 0-2.0 metres.

PART No.	DESCRIPTION
ECONO-BK	Econo-belt – Black
ECONO-RD	Econo-belt – Red
ECONO-BL	Econo-belt – Blue
NEATA-SH	Neata sign holder (A4)
NEATA-WRC	Neata wall receiver clip

### Value features:

- » Economical pricing.
- » Stainless steel construction.
- » Built-in scuff pads to protect floors.
- » Compatible with other systems.
- » Built-in 4-way connectivity.
- » Available in 3 standard colours.
- » Replacement cassettes available.
- » Optional wall receiver clip.
- » Screen printing available.

### Specifications:

<b>Material:</b>	Stainless steel post and skirt. Cast iron base with scuff pads.
<b>Height:</b>	900mm.
<b>Diameter:</b>	Post 63mm / Base 330mm.
<b>Weight:</b>	8kgs.
<b>Extension:</b>	0-2.0 metres.
<b>Delivery:</b>	Flat packed.
<b>Belts:</b>	Black, Red or Blue.



Econo-belt.

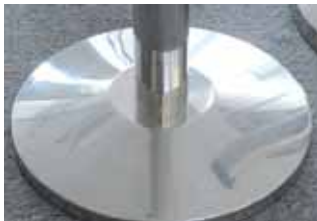

Polished stainless steel.



Built-in scuff pads.



2 metre belt cassette.

## SECTION 7.2

## RETRACTA-BELT – Extreme

Retracta-belt Extreme is the retractable barrier manufactured for extreme environments.

UPVC post with our unique moulded rubber base means the Extreme can be used indoors or outdoors in any conditions.

Particularly useful in harsh or corrosive environments such as aquatic centres etc.

Forget refillable plastic bases, our unique 7.5kg rubber base is always ready for action. Receiver posts (without cassette assembly) are available.

Manufactured with a fully serviceable head and replacement parts readily available.

Retracta-belt Extreme has built-in 2-way connectivity and is compatible with other retractable barrier systems.

With a height of 950mm to top of belt, the post is 63mm diameter while the rubber base is 380mm.

Available with 9 belt colour options, the Retract-belt Extreme is flat packed.

Weight of post and base 8.5kg. Belt extension 0-2.4m.

### Value features:

- » Non-metallic construction for harsh or corrosive sites, indoors or out.
- » Fully serviceable head with spare parts available.
- » 2-way connectivity compatible with other systems.
- » Locking belt ends.
- » Tension adjustable.
- » Available with black base with grey or yellow UPVC post.
- » Available with 9 belt options.
- » Non-marking rubber base is gentle on floors.
- » Optional wall receiver clip.
- » Sign holder – see Section 6.6.

### Specifications:

<b>Material:</b>	Posts – Extruded UPVC plastic 63mm dia., in Grey or Yellow. Base – Black moulded rubber 380mm dia.
<b>Height:</b>	950mm to top of belt.
<b>Diameter:</b>	Post 63mm. / Base 380mm.
<b>Weight:</b>	Approx. 8.5kg per post and base.
<b>Extension:</b>	0-2.4 metres.
<b>Delivery:</b>	Flat packed.
<b>Belts:</b>	Standard colours and options. Refer to Section 7.5.
<b>Signs:</b>	Refer to Section 6.6 for options.



Retracta-belt Extreme.

PART No.	DESCRIPTION
RE	Retracta-belt Extreme UPVC Plastic
RE-POST	Retracta-belt Extreme receiver post
RSH	Retracta-belt sign holder
NEATA-WRC	Neata wall receiver clip

### RETRACTA-BELT – Plus

Retracta-belt *Plus* is our premium retractable belt queue management system. With a choice of high quality polished 304 grade stainless steel finish, or powder coat over stainless steel, and with our unique rubber moulded base with stainless steel skirt to match, this barrier would look at home in the most prestigious environments.

Receiver posts (with no cassette assembly and/or belt) are available. Retracta-belt *Plus* has built-in 4-way connectivity and is compatible with other retractable barrier systems. It is manufactured with a serviceable head and replacement parts are readily available.

With a height of 950mm to top of belt, the post is 63mm diameter while the freestanding base is 380mm in diameter. Available with 9 belt colour options, the Retracta-belt *Plus* is flat packed.

Weight of freestanding post and base 10.5kg. Extension 0-2.4 metres.

Buyers considering this product should also look at the **Econo-belt**. See section 7.1 for more information.

PART No.	DESCRIPTION
RP	Retracta-belt plus stainless steel
RP-POST	Retracta-belt plus stainless steel receiver post
RPP	Retracta-belt plus powder coated
RPP-POST	Retracta-belt plus powder coated receiver post
RSH	Retracta-belt sign holder
NEATA-WRC	Neata wall receiver clip

#### Value features:

- » 2.4 metre belt extension.
- » Durable 304 Grade Stainless steel, 1.6mm thick.
- » Choice of polished stainless steel or powder coat finish over stainless steel.
- » Moulded rubber base, is easy on floors and furniture.
- » Serviceable head with replacement parts readily available.
- » Built-in 4-way connectivity.
- » Compatible with other retractable barrier systems.
- » Locking belt ends.
- » Tension adjustable.
- » Built in sign frame adaptor.
- » Available with 9 belt options.
- » Optional wall receiver clip.

#### Specifications:

<b>Material:</b>	304 grade stainless steel post. Moulded rubber base with stainless steel skirt to match post.
<b>Height:</b>	950mm to top of belt.
<b>Diameter:</b>	Post 63mm x 1.6mm thick. 380mm at base.
<b>Weight:</b>	10.5kgs post and base.
<b>Extension:</b>	0- 2.4 metres.
<b>Delivery:</b>	Flat packed.
<b>Belts:</b>	Standard colours and options. Refer to Section 7.5.
<b>Signs:</b>	Refer to Section 6.6 for options.

PREMIUM 304 GRADE STAINLESS STEEL 1.6MM THICK



### SECTION 7.4

7.3.2 deleted

### PC POST & BASE

Post & Chain is a heavy duty economy post and chain system consisting of a non-marking 7.5kg rubber base with tough, high impact plastic posts. Use Post & Chain with our 6mm plastic chain and our range of signs and holders.

All rubber and plastic construction, makes it ideal for corrosive or industrial applications. Spans up to 3 metres with ease using 6mm plastic chain.

Extruded yellow UPVC 63mm diameter posts with black moulded rubber 380mm base. Height 1000mm to top of post. Weight approximately 8.5kg per post and base. Flat packed.



FOR A FULL RANGE OF PLASTIC CHAINS SEE – OTHER PRODUCTS.

PART No.	DESCRIPTION
PC-G	PC Post and Base – Grey
PC-Y	PC Post and Base – Yellow
SH2	Sign holder and kit to suit PC Post
PC6	6mm plastic chain in 4 colours (see Section 11 for full range)

#### Value features:

- » Extremely stable with the 7.5kg rubber base.
- » Tough extruded UPVC Posts and non-marking rubber base.
- » Not affected by harsh chemicals.
- » Use indoor or outdoor.
- » Posts available in Yellow or Grey.
- » 6mm plastic chain in 4 colours.
- » No need to mess around with water or sand filling of bases.
- » Optional sign adaptor available for use with our range of signs, the SH2.

#### Specifications:

<b>Material:</b>	Post – Extruded UPVC plastic 63mm dia., in grey or yellow. Base – Black Moulded rubber 380mm dia.
<b>Height:</b>	1000mm to top of post.
<b>Diameter:</b>	Post 63mm. / Base 380mm.
<b>Weight:</b>	Approx. 8.5kg per post and base.
<b>Span:</b>	Up to 3 metres using 6mm plastic chain.
<b>Delivery:</b>	Flat packed.
<b>Signs:</b>	Refer to Section 6.6 for options.



SH2 sign holder.



PC-Y Post & Chain shown.

## RETRACTA-BELT OPTIONS

(Plus & Extreme only)



### Printed belts

Custom printing of belts is a high profile way to promote your logo or business.

PART No.	DESCRIPTION
RSP24	Screen printing per belt – 2.4 metre
RSP76	Screen printing per belt – 7.6 metre
RSPA	Printing setup per print job



### Serviceable head

Unlike most other heads that must be discarded if damaged, the Retracta-belt Plus head is fully serviceable. (Excludes Econo-belt).



**Note:** Belt selection for all models except Economy model which is available in Black, Red and Blue only.

07

## See also Section 11 AIRPORT BARRIERS



### The complete queue management system

“ I am very impressed with this Barrier system.



We have recently installed 38 Neata barriers in our customs area for passenger queue control. Neata barriers were selected because they provide a visually pleasing appearance, while still giving the flexibility of conventional free standing barriers. Their unique in-built compression feature allows them to absorb impacts and spring back. They also take up far less space due to their small footprint and they cannot be moved around by cleaners or other individuals, which means they stay looking neat and tidy at all times. ”

Terminal Services Manager  
Wellington International Airport

## Q-CONTROL

Q-Control is available in two models – *Q-Control Plus* which is our premium post and rope system and *Q-Control* which is our economy post and chain system.

**Q-Control Plus:** Aluminium posts in a brushed stainless steel look with stainless steel skirts over rubber bases. Typical high end applications include hotels, entertainment venues and hospitals etc.

**Q-Control:** Red powdercoated posts with solid rubber bases, used with ropes and plastic chain. Ideal for controlling pedestrian movement or barricading hazardous areas around factories or warehouses etc.

**Ropes:** High quality braided ropes 1.5 metres long with chrome dog clips. Available in four standard colours. Custom ropes up to 2.5 metres can be supplied upon request.

**Wall bracket:** A chrome plated wall receiver bracket for use with ropes. Accepts chrome dog clip.

**Sign holder & signs:** Machined from solid steel and chrome plated, this high quality sign holder accepts our range of engraved signs. For a complete list of standard sign legends see Section 6.6.

**Plastic chain:** 6mm plastic chain in Yellow, Red, White or Red/White available by the metre or by the 25 metre roll. See Section Other Products for our full range.

### Value features:

- » Choice of two styles.
- » Durable post and base combinations.
- » Lightweight with stability.
- » A range of ropes and chains.
- » Spun stainless steel skirt ('Plus' model only).

### Specifications

<b>Description:</b>	Post and base system.
<b>Material:</b>	Posts – 40mm dia., 2.5mm wall, 940mm high (Aluminium). Bases – Moulded rubber 300mm dia. Skirt – 304 Grade spun stainless steel ('Plus' model only).
<b>Weight:</b>	Approx. 4kgs per post and base.
<b>Ropes:</b>	Standard 1.5 metres long braided rope with chrome dog clips.



Q-Control Plus – premium post and rope system (QCX).



Q-Control Economy – premium post and chain system (QC).



Quality braided ropes with dog clips.



Chrome wall bracket.

PART No.	DESCRIPTION
QCX	Q-Control Plus – premium post and base
QC	Q-Control – economy post and base
QCROPE-RED	Q-Control rope Red 1.5 metres long
QCROPE-BLU	Q-Control rope Blue 1.5 metres long
QCROPE-BUR	Q-Control rope Burgundy 1.5 metres long
QCROPE-BLK	Q-Control rope Black 1.5 metres long
QCR-CUS	Custom Q-Control rope up to 2.5 metres long
QCWB	Wall mount bracket
QCH	Sign holder for Q-sign range
PC6	6mm plastic chain in 4 colours (see Other Products for full range)



Sign holder & signs.  
(See Section 6.6 for full range).



6mm plastic chain.  
(See Other Products for full range).

## RETRACTA-BELT 2.4 METRE WALL MOUNT

Compact and robust design makes this wall mount ideal for tight locations such as supermarket check out, hallways or aisles. It can even be mounted inside a cupboard with just the belt exposed.

## RETRACTA-BELT 7.6 METRE WALL MOUNT

Retracta-belt Wall Mount units are designed for wall mounting where floor space is limited or post and base units are not appropriate. This model is particularly useful in large span situations such as warehouse aisle closures and loading docks etc.

### Specifications

<b>Material:</b>	RWM24 – Powder coated steel housing. RWM76 – Powder coated alum. housing.
<b>Weight:</b>	RWM24 – 700 grams. RWM76 – 1.2kg.
<b>Extensions:</b>	RWM24 – 0-2.4 metres RWM76 – 0-7.6 metres
<b>Delivery:</b>	Individually packaged with fixings and wall receiver end.
<b>Belt:</b>	Standard colours. See Section 7.5.
<b>Installations:</b>	Permanent. Screw fixed.

**! BELT OPTIONS: See Section 7.5**



2.4 metre wall mount – RWM24.



7.6 metre wall mount models – RWM76.



PART No.	DESCRIPTION
RWM24	Retracta-belt wall mount 2.4m
RWM76	Retracta-belt wall mount 7.6m
RWR	Additional wall receiver clip
NEATA-WRC	Neata wall receiver clip

## SECTION 7.8

## RETRACTA-BELT 7.6 METRE MAGNA MOUNT

The Magna-mount has all the features of the 7.6 metre wall mount model in Section 7.7, with the added flexibility of being able to be quickly repositioned, using the magnetic base mount and magnetic belt clip.

Safety bungy prevents damage if the Magna-mount is accidentally dislodged.

### Specifications

<b>Material:</b>	Powder coated alum. housing.
<b>Weight:</b>	1.5kg.
<b>Extension:</b>	0-7.6m.
<b>Delivery:</b>	Complete with magnetic base and belt clip.
<b>Belt:</b>	Standard colours. See Section 7.5.
<b>Installation:</b>	Semi-Permanent. Magnetic fixed.

PART No.	DESCRIPTION
RMM76	Retracta-belt Magna-mount 7.6m



Magnetic base mount.



Safety bungy.



Magnetic belt clip.

## SKIPPER – 9 metre retractable tape barrier

Skipper™ is a unique, purpose designed approach to traffic and facilities management. It allows you to cordon off hazardous or restricted areas indoors or outside quickly and cost effectively. Skipper's fully retractable 9 metre tape enables all areas to be closed off using standard weighted-base cones or UPVC posts.

Simply fit Skipper over the top of your cone or post or, if you wish, Skipper can be screwed to the cone for greater security. Alternatively, using our optional wall mount bracket, Skipper can be used to block doorways, close off aisles in warehouses or anywhere that requires a fixed barrier.

Also available is a switchable warning light with built-in daylight sensor.

### Value features:

- » Full 9 metre retractable tape.
- » Push button tape lock to prevent tampering.
- » Tough, corrosion proof moulded housing.
- » Four way connectivity.
- » Unique belt clip allows belt to hook back onto itself.
- » Fits standard 1 metre traffic cones or UPVC posts.
- » High visibility Red/White or Black/Yellow tape.
- » Wall mount bracket available.
- » Optional emergency light.
- » Optional sign holders and signs.

### Specifications:

<b>Description:</b>	9 metre retractable barrier.
<b>Material:</b>	Housing – High impact polypropylene. Tape – Reinforced nylon with water repellent coating.
<b>Tape finish:</b>	Red/white or black/yellow diagonal stripes.
<b>Tape Length:</b>	9 metres.
<b>Housing:</b>	250mm high x 150mm in diameter.
<b>Weight:</b>	SKIP-BY/RW – 0.7kgs.



The Skipper allows you to cordon off hazardous or restricted areas indoors or outside.



Red and White (SKIP-RW).



Black and Yellow (SKIP-BY).



See also 'Magna Mount' Section 7.8.



See also 'Port-a-guard' Section 6.

PART No.	DESCRIPTION
SKIP-RW	Skipper 9 mtr retractable barrier (Red/White)
SKIP-BY	Skipper 9 mtr retractable barrier (Black/Yellow)

### How it works



Fit Skipper onto top of the cone or post & base unit. Secure with screws if required.



Pull the tape out to the desired length.



Clip the tape to the next skipper or receiver unit.



Lock the tape button to prevent unwanted spooling.

## SECTION 7.9.2

### SKIPPER ONE METRE CONE

A 1 metre high stackable cone manufactured from tough polyethylene with a heavy rubber base for stability and reflective collar for improved visibility. Skipper simply fits over the cone and can be screw fixed for extra security if required. Belt height 1090mm. (Skipper not included).

### CONE MOUNT RECEIVER UNIT

This receiver unit is a press fit onto our 1 metre cone.

For extra security use the fixing screws provided.

Features include solid aluminium construction with anodised finish and two-way connectivity allowing 2

Skipper units to span up to 18 metres. A twist and lock cap prevents belts dislodging in windy conditions.

PART No.	DESCRIPTION
BTC1000R	Skipper 1 metre cone
SKRCA	Cone receiver unit (order separately)



1 metre cone (BTC1000R).



Cone Mount Receiver (SKRCA).

## SECTION 7.9.3

### SKIPPER POST & BASE

A post & base unit designed to accept the Skipper unit. The UPVC posts are available in yellow or grey and are 63.5mm in diameter. The heavy rubber base offers stability. Belt height 990mm. (Skipper not included).

### RECEIVER POST

A receiver post to compliment the Skipper post & base above. Features include, solid aluminium construction, anodised finish, two-way connectivity. A twist and lock cap prevents belts dislodging in windy conditions. (Includes post, base and receiver head).

PART No.	DESCRIPTION
SKPBY	Skipper post & base – Yellow
SKPBG	Skipper post & base – Grey
SKPRP-Y	Skipper receiver post & base – Yellow
SKPRP-G	Skipper receiver post & base – Grey



UPVC Post & Base.  
(Grey or Yellow).



UPVC Receiver post & base.  
(SKPRP-G or SKPRP-Y).

## SECTION 7.9.4

### SKIPPER WALL MOUNT

The Skipper wall mount bracket allows Skippers to be used without the need for cones or posts and can be mounted to walls or columns. It is manufactured from heavy steel components and zinc plated to resist rust. (Skipper not included).

### WALL MOUNT RECEIVER UNIT

This belt receiver unit can be mounted to any wall or column. It is compatible with Skippers mounted on cones, post & base units or wall mount brackets. Manufactured from aluminium with an anodised finish, it is both compact and attractive.

PART No.	DESCRIPTION
SKWM	Skipper wall mounted bracket
SKRC	Wall mounted receiver unit



Skipper wall mount (SKWM).



Wall mount receiver (SKRC).

## PEDESTRIAN CONTROL

### SKIPPER SIGN HOLDER

A sign holder to suit the Skipper that is both practical and attractive. Machined from solid steel and bright chrome plated for a high quality finish, this sign holder allows you to mount signs directly into the top of the Skipper. The sign fits securely into the machined slot and is held in place by a concealed grub screw. (Supplied complete with hex key). Requires 6mm hole to be drilled in the skipper cap.

### SKIPPER SIGNS

A range of engraved signs manufactured from premium brushed silver laminate with black legends. They measure 190 x 275mm. For the full range see Section 6.6.



Skipper sign holder (QCH).



See Section 6.6 for sign range.

PART No.	DESCRIPTION
QCH	Sign holder

**SECTION 7.9.6**



### SKIPPER LIGHT

A multi function LED warning light that is fully rechargeable. Powered by 6 AA Batteries (not included), it is switchable between permanent or flashing mode, it also has a light sensor for automatic low light activation, which can be turned off. The light unit simply replaces the top housing cap on your existing Skipper for a fully integrated design.

Reflective side panels assist low light visibility. (Light and Skipper sold separately).



Reflective surfaces.



Sensor & flash switches.



Skipper multi-function light (SKLIGHT).

PART No.	DESCRIPTION
SKLIGHT	Skipper multi function light (Amber)

**SECTION 7.9.7**

### STANDARD TAPES

Our standard Skipper tapes are all manufactured from a durable, dip coated, woven polyester fabric and are virtually un-rippable. They are available in diagonal Red/White or Black/Yellow stripes.

### CUSTOM TAPES

Made to the same specifications as our standard tapes. These are available in up to 4 colours for logos, promotions or warning messages. Minimum quantities and additional costs may apply. Lead times of 4 to 6 weeks apply.



Standard tapes.



Custom printed tapes. POA.

## EVENT FENCE

Event Fence portable barrier is a system of interlocking free standing fence panels. Strength, durability and flexibility are all features of Event Fence! Simply link Event Fence panels together to create continuous barricading for festivals, parades, sporting events or work sites.

Optional forklift stillage make storage and transporting of Event fence panels simple and efficient.

### Value features:

- » Fully welded steel construction.
- » Galvanised finish.
- » Panels nest together when not in use to reduce storage space.
- » Feet are removable if desired for freight or storage.
- » Vertical bars eliminate climbing points.
- » Panels are able to pivot at joints.
- » Low profile feet reduce tripping hazards.

### Specifications:

<b>Description:</b>	Modular and portable temporary barrier system.
<b>Material:</b>	Steel construction, fully welded.
<b>Finish:</b>	Hot dip galvanised.
<b>Length:</b>	2200mm.
<b>Width:</b>	490mm.
<b>Height:</b>	1100mm.
<b>Weight:</b>	16kgs.
<b>Installation:</b>	Free standing panels, link together. No tools required.

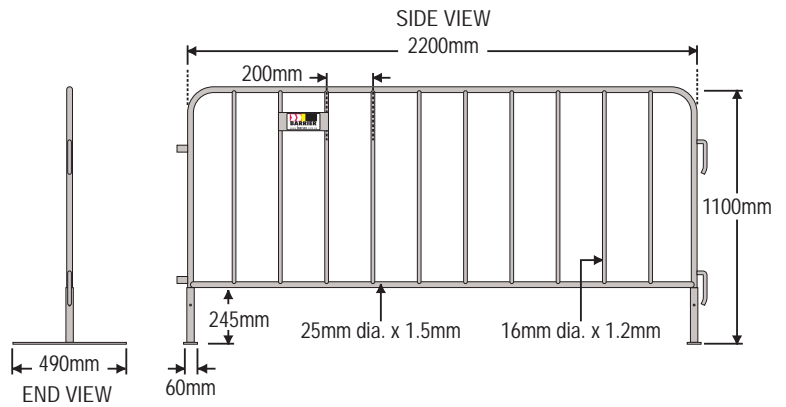

### HANDY TIP

Buyers considering purchasing event fence should also consider our EFS stackable forklift stillages. These stillages make the storage and handling of event fence panels much more space efficient and easier to handle. EFS (Optional) stackable forklift stillage. Designed to hold 30 x EF25/200. For more information see Section 7.10.2.

PART No.	DESCRIPTION
EF25/200	Standard Duty Event Fence
EFS	Event Fence Forklift stillage – stackable

## SECTION 7.10.2

### EVENT FENCE STILLAGES

Optional fork lift stillages make the storage, handling and transportation of large numbers of Event Fence panels simple and efficient.

These robust hot dip galvanised steel stillages hold either 30 pieces of the EF25/200 standard duty event fence panels or 14 Crowd-Q Panels.

### Value features:

- » Robust construction with galvanised finish.
- » Designed for use with forklifts.
- » Stackable to 4 units high.
- » Each unit holds up to 30 Event Fence panels.
- » Panels can be hand loaded by one person.

PART No.	DESCRIPTION
EFS	Event Fence stackable forklift stillage



EFS – Stillages make storage and handling of panels simple and space efficient.

### CROWD-Q

Crowd-Q is a system of portable interlocking free standing fence panels for crowd management. Crowd-Q is manufactured from super tough and light weight moulded polyethylene in hi-visibility safety orange. Maximum panel openings of 80mm ensure small children are unable to climb through or under. Other features include stacking dimples, built-in reflective panels and low profile feet that rotate for transport or stacking. Panels link together to create continuous barricading for festivals, parades, sporting events and work sites. Optional forklift stillages holding up to 14 Crowd-Q panels makes handling and transporting simple and efficient. See Section 7.10.2.

#### Value features:

- » Child safe 80mm panel openings.
- » Low profile folding feet with fixing holes.
- » Super tough polyethylene in hi-viz orange.
- » Light weight for ease of handling.
- » Sliding panel connector for sloping ground.
- » Built-in reflective panels.

#### Specifications

<b>Description:</b>	Portable interlocking crowd control system.
<b>Material:</b>	Moulded polyethylene.
<b>Finish:</b>	Solid colour. Hi-viz safety orange.
<b>Height:</b>	1000mm.
<b>Length:</b>	2130mm.
<b>Thickness:</b>	60mm.
<b>Weight:</b>	Approx. 14kgs per unit.
<b>Installation:</b>	Free standing, linked panels.

PART No.	DESCRIPTION
CQ2130	Crowd-Q portable event fence
EFS	Event fence forklift stillages – stackable



Light weight, durable and easily handled by one person.



Crowd-Q panels stack flat for ease of transport.



Rotating foot with fixing hole.



Sliding panel connector for uneven ground.

**WARNING**

© Barrier Group Pty. Ltd. takes the protection of its intellectual property (IP) seriously and will not hesitate to pursue legal action against any individual, group or organization attempting to steal, copy or duplicate any of its proprietary designs OR anyone who imports, sells or distributes illegal copies or duplicates of its proprietary designs.

**IT'S AGAINST THE LAW – AVOID THE PAIN!**

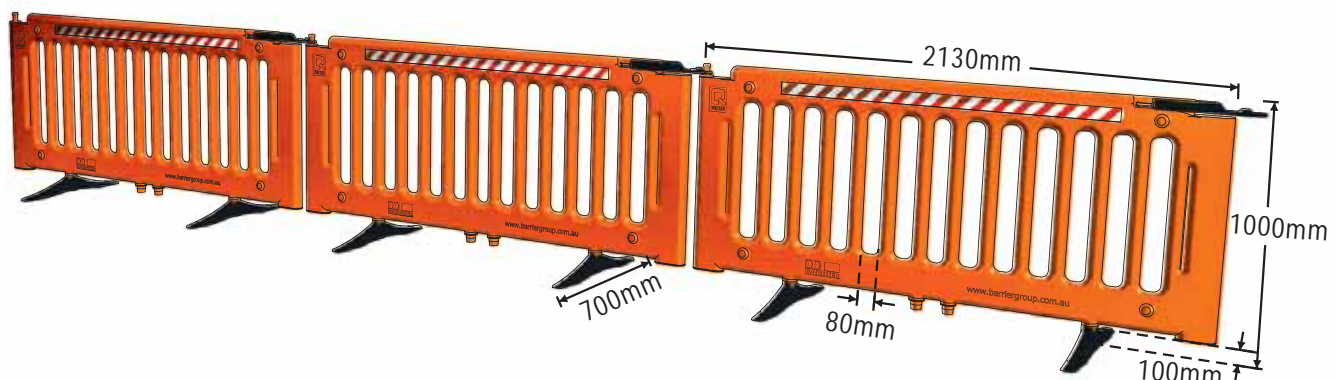

# LEGEND



## AUSTRALIAN CONTENT

This product has been designed, developed and is either completely or substantially manufactured in Australia. (The minimum Australian content is between 50 and 100%).



## NEW AND UNIQUE

This is a new and unique product. It has either been designed, developed and manufactured by the Barrier Group Pty. Ltd. or it is being seen here for the first time.



## 100% RECYCLABLE

This product is manufactured from virgin grade raw materials and is 100% recyclable using existing, readily available recycling technology and services.



## RECYCLED MATERIALS

This product has been manufactured from either a combination of recycled materials and virgin grade materials or entirely from recycled materials.



## HOT DIP GALVANISED

This product has been hot dip galvanised prior to any surface coatings being applied. Hot dip galvanised offers vastly improved corrosion protection and extended life in harsh environments.



## FIXINGS INCLUDED

This product comes complete with all the necessary fixings to complete the standard installation. When comparing competitors prices against our own, always ensure they have included the fixings with the product (excludes gravel spikes).



## 5 YEAR WARRANTY

This product carries a 5 year limited warranty against structural failure due to faulty materials or workmanship in our manufactured products, OR structural failure and major fading due to U.V. degradation in our injection moulded products.

(For full conditions visit [www.barriergroup.com.au](http://www.barriergroup.com.au)).

# WARNING

© Barrier Group Pty. Ltd. takes the protection of its intellectual property (IP) seriously and will not hesitate to pursue legal action against any individual, group or organization attempting to steal, copy or duplicate any of its proprietary designs OR anyone who imports, sells or distributes illegal copies or duplicates of its proprietary designs.

**IT'S AGAINST THE LAW – AVOID THE PAIN!**