



POST AND RAIL – Heavy duty

Post & Rail is a modular barrier system for use in car parks, factories, shopping centres, etc. or anywhere vehicles and pedestrians need to be segregated. Posts are 1050 high above ground. Rails are available in 2, 3, or 6 metre lengths. The modular design of 'Post & Rail' ensures barriers can be quickly erected with a minimum of disruption. Suitable for either flat or sloping surfaces.

Value features:

- » Super strong 90mm or 140mm diameter posts with 5mm thick walls.
- » 6mm thick base plates with 4 bolt fixing.
- » Powder coated finish.
- » Sculpted hand rails in a range of lengths.
- » Suitable on slopes or ramps.

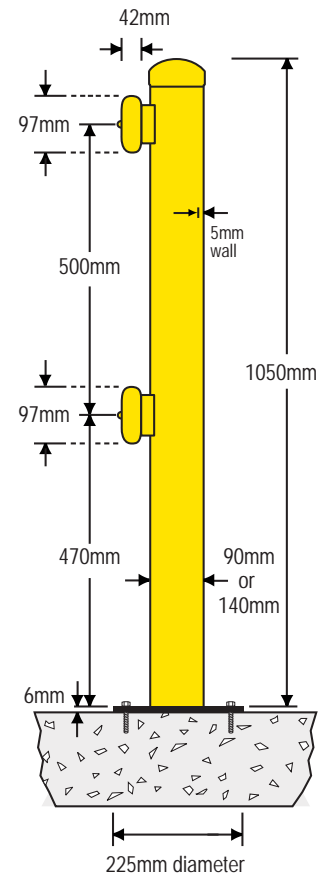

Specifications

Description:	Modular Post & Rail system.
Material:	Posts 90 or 140mm diameter, 5mm wall. Rails 97 x 42mm tube, 2.5mm wall.
Finish:	Safety yellow powder coat.
Height:	Post height 1050mm above ground / Rail centres 500mm.
Rail lengths:	2, 3, or 6 metres.
Weight:	Posts 90mm 9kg, 140mm 25kg, Rails 4.25kg per metre.
Installation	4 x 12mm masonry anchors per post.

PART No.	DESCRIPTION
PR90SMD	Surface mount post 90mm diameter
PR140SMD	Surface mount post 140mm diameter
PR90BGD	In-ground post 90mm diameter
PR906	6 metre rail (replacement) requires 3 posts
PR903	3 metre rail (replacement) requires 2 posts
PR902	2 metre rail (replacement) requires 2 posts

SECTION 2.4

ECONO-RAIL – Standard duty

Econo-rail is a flexible and economical pedestrian control system that is simple to install. It consists of surface mount posts and rails in 1, 1.5 or 2 metre lengths. Alternatively, rails can be cut to length. The system comes complete with connectors and fixings. Ideal where an attractive and practical solution is required to control the movement of pedestrians.

Value features:

- » Powder coated rails available in three standard lengths or can be cut down on site.
- » Comes with all fittings and fixtures.
- » Rails can come off posts at any angle for changes in direction using our unique post to rail adapters.
- » Highly visible safety yellow powder coated finish.
- » Can be custom powder coated, if required (May incur extra costs).



Specifications

Description:	Modular economy post & rail system.
Material:	Posts 63.5mm diameter, 1.6mm wall, 1050 high. Rails 31 x 59mm oval galvanised tube with 1.6mm wall.
Finish:	Safety yellow powder coat.
Height:	Post height 1050mm.
Rail lengths:	1, 1.5, or 2 metres.
Weight:	Posts 4kg / Rails 2kg metre.
Installation	3 off 10 x 50mm masonry anchors per post.

PART No.	DESCRIPTION
ER63-SM	Surface mount post
ER631	1 metre rail with connectors
ER6315	1.5 metre rail with connectors
ER632	2 metre rail with connectors