

Replaces all previous versions

Effective 1st January 2007 - Catalogue '07 page 13

## Plastic Wheel Stops

### Specifications

Description:	Recycled plastic wheel stop.
Material:	Recycled plastic.
Finish:	Solid colour
Length:	1650mm.
Width:	135mm.
Height:	95mm.
Installation:	9kgs.
No. of fixing:	3 x 150mm Masonry anchors, or Asphalt spikes.

Suitable in all parking areas to avoid damage to vehicles or property caused by vehicles over-shooting parking bays. These tough wheel stops are manufactured from recycled plastic. They won't chip or rust, and they come complete with fixings.

The low height of 95mm ensures that vehicles with low clearance will not be damaged as they can be with taller concrete wheel stops.

Also suitable for use in factories and warehouses to prevent trolleys and forklifts from bumping into walls or offices etc...

### Value Features

- \* Designed to comply with AS2890.1:2004.
- \* Can be fixed to concrete or asphalt.
- \* Economical and simple to install.
- \* Solid moulded construction.
- \* Recycled plastic won't chip or corrode.
- \* Mounting holes moulded in.
- \* Low profile reduces the risk of damage to parking vehicles.
- \* Can easily be removed or repositioned at any time.
- \* Comes complete with fixings.
- \* Available in grey or yellow.

PART No.	DESCRIPTION
PWS1650	1650mm with fittings - Grey
PWS1650Y	1650mm with fittings - Yellow

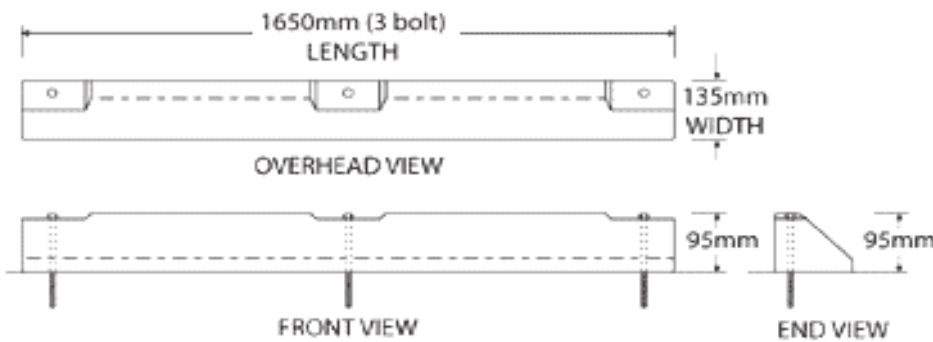

## Wheel Chocks

PART No.	DESCRIPTION
WC1	255 x 210 x 180mm
WC2	200 x 145 x 250mm
WC3	305 x 260 x 300mm

High quality rubber wheel chocks suitable for use in the truck, bus and aviation industries

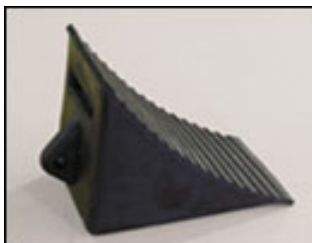

WC1

A high quality moulded rubber wheel chock measuring 255mm long x 210mm high and 180mm wide. Rope connection points moulded into the chock. Single side design. Weight 4.5kgs

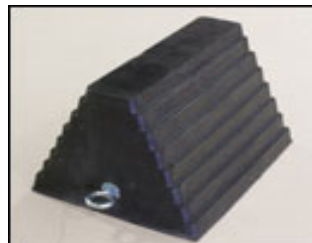

WC2

Moulded from high quality rubber, this wheel chock has a double sided design. This makes for easy installation especially when positioned between dual axle trucks or trailers. Includes rope attachment points 200mm long x 145mm high x 250 wide. Weight 3.75kgs

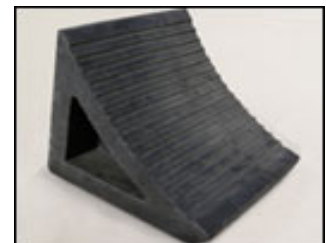

WC3

Super heavy duty truck chock 305mm long x 260mm high x 300mm wide. Weight 11.8kgs

Please e-mail to [spacepac@spacepac.com.au](mailto:spacepac@spacepac.com.au) for more information and current pricing

All prices/specifications subject to change without notice.